

Agenda

Name of meeting	LICENSING SUB COMMITTEE
Date	FRIDAY 22 MARCH 2024
Time	10.30 AM
Venue	COUNCIL CHAMBER, COUNTY HALL, NEWPORT, ISLE OF WIGHT
Members of the committee	Cllrs M Beston (Chairman), D Andre and J Bacon
	Democratic Services Officer: Sarah MacDonald democratic.services@iow.gov.uk

1. **Apologies and Changes to Membership (if any)**

To note any changes in membership of the Committee made in accordance with Part 4B paragraph 5 of the Council's Constitution.

2. **Minutes** (Pages 5 - 8)

To confirm as a true record the Minutes of the meeting held on 13 November 2023.

3. **Declarations of Interest**

To invite Members to declare any interest they might have in the matters on the agenda.

4. **Urgent Business**

To consider any matters which, in the Chairman's opinion, are urgent.



Details of this and other Council committee meetings can be viewed on the Isle of Wight Council's Committee [website](#). This information may be available in alternative formats on request. Please note the meeting will be audio recorded and the recording will be placed on the website (except any part of the meeting from which the press and public are excluded). Young people are welcome to attend Council meetings however parents/carers should be aware that the public gallery is not a supervised area.

5. **Report of the Strategic Director of Community Services**

- (a) Application for a Street Trading Consent for The Salty Siren at Princes Esplanade, Gurnard, Isle of Wight (Pages 9 - 56)

CHRISTOPHER POTTER
Monitoring Officer
Thursday, 14 March 2024

Interests

If there is a matter on this agenda which may relate to an interest you or your partner or spouse has or one you have disclosed in your register of interests, you must declare your interest before the matter is discussed or when your interest becomes apparent. If the matter relates to an interest in your register of pecuniary interests then you must take no part in its consideration and you must leave the room for that item. Should you wish to participate as a member of the public to express your views where public speaking is allowed under the Council's normal procedures, then you will need to seek a dispensation to do so. Dispensations are considered by the Monitoring Officer following the submission of a written request. Dispensations may take up to 2 weeks to be granted.

Members are reminded that it is a requirement of the Code of Conduct that they should also keep their written Register of Interests up to date. Any changes to the interests recorded on that form should be made as soon as reasonably practicable, and within 28 days of the change. A change would be necessary if, for example, your employment changes, you move house or acquire any new property or land.

If you require more guidance on the Code of Conduct or are unsure whether you need to record an interest on the written register you should take advice from the Monitoring Officer – Christopher Potter on (01983) 821000, email christopher.potter@iow.gov.uk, or Deputy Monitoring Officer - Justin Thorne on (01983) 821000, email justin.thorne@iow.gov.uk.

Notice of recording

Please note that all meetings that are open to the public and press may be filmed or recorded and/or commented on online by the council or any member of the public or press. However, this activity must not disrupt the meeting, and if it does you will be asked to stop and possibly to leave the meeting. This meeting may also be filmed for live and subsequent broadcast (except any part of the meeting from which the press and public are excluded).

If you wish to record, film or photograph the council meeting or if you believe that being filmed or recorded would pose a risk to the safety of you or others then please speak with the democratic services officer prior to that start of the meeting. Their contact details are on the agenda papers.

If the press and public are excluded for part of a meeting because confidential or exempt information is likely to be disclosed, there is no right to record that part of the meeting. All recording and filming equipment must be removed from the meeting room when the public and press are excluded.

If you require further information please see the council guide to reporting on council meetings which can be found at <http://www.iwight.com/documentlibrary/view/recording-of-proceedings-guidance-note>

All information that is recorded by the council is held in accordance with the Data Protection Act 2018. For further information please contact Democratic Services at democratic.services@iow.gov.uk



Minutes

Name of meeting	LICENSING SUB COMMITTEE
Date and Time	MONDAY 13 NOVEMBER 2023 COMMENCING AT 10.00 AM
Venue	COUNCIL CHAMBER, COUNTY HALL, NEWPORT, ISLE OF WIGHT
Present	Cllrs D Andre, J Bacon and C Mosdell
Also Present	Andrea Bull, Ben Gard, Kevin Winchcombe and Mark Wootton
Apologies	Cllrs J Jones-Evans

26. Election of Chairman for the day

Cllr Bacon was nominated and duly seconded.

RESOLVED:

THAT Cllr Bacon was elected Chairman

27. Apologies and Changes to Membership (if any)

An apology was received from Cllr Julie Jones-Evans (Committee Member), and was replaced by Cllr Mosdell.

28. Declarations of Interest

There were no declarations of interest.

29. Urgent Business

There were no items of Urgent Business.

30. Report of the Director of Strategic Director of Community Services

31. Application for a variation to a premises licence under section 34 of the Licensing Act 2003 for Ephesus Pizza Grill, 137 High Street, Newport, Isle of Wight, PO30 1TY

The Licensing Officer presented the report and summarised the application.

The Committee noted that conditions proposed by the police had been agreed by the applicant. Children's Services requested a Safeguarding Policy to be completed but the applicant had not yet responded.

Environmental Health raised concerns around the application and following further advice from the police, recommended the licence should be extended to 2.30am.

The applicant confirmed a Safeguarding Policy would be provided and staff trained to know what do if they have concerns seeing children on or around the premises late at night. Security would also be employed to address anti-social behaviour on the premises.

The applicant confirmed they did not have an alcohol licence and would only be providing food.

The objectors advised the Committee of the concerns they had regarding the application.

The Committee noted the trading times of other establishments in the area.

The Committee retired to private session to consider their decision, and upon reconvening it was:

RESOLVED:

THAT upon receiving the report of the licensing section, oral and written evidence from the applicant, responsible authorities, and other persons, and having regard to the Guidance issued under s182 of the Licensing Act 2003 and the Isle of Wight Council's Statement of Licensing Policy, the sub-committee hereby:

Grant the licence in accordance with the application, subject to those conditions proposed by the applicant within the operating schedule and also subject to the mandatory conditions specified in the Licensing Act 2003 but modified to such an extent as members have considered appropriate for the promotion of the 4 licensing objectives, namely by requiring the following conditions:

- i) That the hours or the provision of late-night refreshment shall be amended as follows:-
 - Friday – 2300-0230 hrs
 - Saturday – 2300-0230 hrs
 - New Year's Eve into New Year's Day – 2300-0230 hrs
- ii) The inclusion of those conditions agreed with the police at appendix 4 of the Report per the reasons given within the same report but modified as follows:-
 - Condition 1 – The public are not permitted to remain on the premises after 0030 hrs on Monday to Friday or 0300 hrs Saturday and Sunday and New Years Day.

- iii) The inclusion of a condition as follows:-
- No licensable activity hereby approved shall be permitted until a policy for the protection of children been submitted to and approved in writing by the Licensing Authority which shall as a minimum include:-
 - The safeguarding of children;
 - The training of staff in respect of children in the event of children attending the premises alone or in circumstances where concern may arise; and,
 - A procedure for escalation of safeguarding concerns.

Reason:

The conditions were attached as per reasons given within same report in order to promote the Licensing objectives protection of children from harm, the prevention of crime and disorder, and the prevention of public nuisance and in accordance with the Isle of Wight Councils Statement of Licensing Policy and the section 182 guidance.

In reaching the above decision the sub-committee had regard to the Human Rights Act 1998, and in particular Article 1 of the First Protocol, Article 8 and Article 6. The sub-committee considered this decision was proportionate and appropriate for the promotion of the 4 licensing objectives under the Licensing Act 2003.

There was a right of appeal to the Magistrates Court if anyone is dissatisfied with this decision and any appeal must be made within 21 days of the date of notification.

CHAIRMAN

This page is intentionally left blank

Committee Report

Committee	LICENSING SUB COMMITTEE
Date	FRIDAY 22 MARCH 2024
Title	TO DETERMINE AN APPLICATION FOR A STREET TRADING CONSENT UNDER SCHEDULE 4, LOCAL GOVERNMENT (MISCELLANEOUS PROVISIONS) ACT 1982 FOR THE SALTY SIREN, PRINCES ESPLANADE, GURNARD, ISLE OF WIGHT.
Report Author	COLIN ROWLAND STRATEGIC DIRECTOR COMMUNITY SERVICES

Background

1. A street trading consent authorises the holder of a consent to sell, expose or offer for sale any article (including a living thing) in the street.
2. For the purposes of street trading a Street includes:
 - any road, footway, beach or other area to which the public have access without payment; and
 - a service area as defined in section 329 of the Highways Act 1980.
3. An application for a street trading consent is made to a council under Schedule 4 to Part III of the Local Government (Miscellaneous Provisions) Act 1982 (the Act).
4. Paragraph 1 of Schedule 4 of the Act defines a “consent street” as a street in which street trading is prohibited without the consent of the district council.
5. An application for a street trading consent was submitted by Ms Carly Sykes on 22 January 2024 (Appendix 1) for permission to trade on Princes Esplanade, Gurnard, Isle of Wight.
6. A plan submitted with the application shows the proposed trading location. (Appendix 2). Two locations were selected in order of preference.
7. Ms Sykes’ business is known as ‘The Salty Siren’. Items that are proposed to be sold include ice creams, lollies, tea and coffee, slushies, popcorn, pre-packaged baked goods along with buckets, spades, crabbing nets and beach shoes.
8. When the application was first submitted, it was proposed that trading would take place from a converted horsebox. However, since this time the applicant

has purchased a catering pod which is purpose built for this activity. Specific dimensions and a photograph of the catering pod can be found at Appendix 3.

9. Ms Sykes has applied for a 12 month consent commencing on 20 May 2024, for trading each day between 9am and 5pm, Monday to Saturday and from 10am to 4pm on Sunday.

Consultation

10. The Isle of Wight Council Street Trading Policy 2022 - 2024 prescribes a twenty one day consultation period, commencing the day after the application has been correctly served. Applicants are required to advertise the application on site and in a local newspaper.
11. This application for a street trading consent was received on 22 January 2024. Consultation commenced on 23 January 2024 and ended on 12 February 2024.
12. The application was advertised in the Observer on 26 January 2024 and at the proposed trading location.
13. Throughout the consultation period the application has been available to view on the council's website.

Responsible Authorities

14. The licensing department consult with relevant authorities. The outcome of the consultation is as follows:

Responsible Authorities	
Environmental Health	No adverse comment to the application. Further comments made on request of licensing officer in response to representations received. These are referenced later in the report.
Fire and Rescue Service	No Representation made
Police	No Representation made
NHS	No Representation made
Planning Services	No Representation made
Highways	No objections. Request made that the unit when parked faces in the direction of travel to protect both the unit and the drivers.

Other Persons

15. 19 representations were received during the consultation opposing the application. Many of the comments submitted cannot be considered as part of

the determination and therefore the document has been redacted to show only relevant comments or those that require commenting on in accordance with the IWC Street Trading Policy. This document can be found at Appendix 4.

16. In determining an application for the grant or renewal of street trading consent the licensing authority will consider the following:
 - a) Public Safety
 - b) Prevention of Crime and Disorder
 - c) Prevention of Public Nuisance
 - d) Protection of Children from Harm
 - e) The Visual Impact
17. In respect of Public Safety and the Protection of Children from Harm – concerns have been raised that the fumes, noise, and vibrations of the generator pose a risk to the public and employees along with the risks involved with refuelling in this location.
18. One objector states that she has hidden disabilities and the impact of a generator, smell, noise and vibrations will have an impact on her safety.
19. Concerns have also been raised in respect of road safety around children wandering off to buy beach items, crossing the road on a bend and congestion of the pavement if there is a queue of customers waiting to be served.
20. A further comment received states that “The application suggests a permanent fixture and this will bring a criminal element to the area which is dark and unlit at night. As a woman I can safely walk along the esplanade at night but this would deter me and I am afraid for my safety.”
21. In respect of Crime and Disorder- concerns have been raised that if the trading unit is left in situ overnight that it could “encourage youths to commit crimes. They will know that there will be items left on the vehicle and may try to break into it to retrieve them.”
22. In respect of Public Nuisance – concerns have been raised around the use of a generator, particularly in relation to noise, fumes and vibrations that may be omitted. Local residents are concerned that a generator running all day will impact on the enjoyment of their homes and gardens.
23. Concerns have also been raised in respect of litter. Objectors perceive that the granting of a consent will lead to an increase in litter along the seafront, which will have an impact on residents and visitors, as well as endangering local wildlife. Concerns have also been expressed that an increase in litter may attract vermin.
24. With regards to the use of the generator, comments have been received stating that a generator should not be used in rain or wet conditions, and that it needs to stay dry. Also that there is a risk from chemicals leaking from a flooded generator which may cause damage to public foot paths and wildlife.”
25. Also, in respect of public nuisance, concerns have been raised that this location “requires pumping of all black and grey water and therefore any waste from this caravan can only be discharged into the sea.”

26. Finally in respect of nuisance, concerns have been raised that the trader will take up valuable parking spaces and this may lead to an increase in illegal parking or the blocking of resident's drives.
27. In respect of visual impact – concerns were initially raised that a converted horsebox was not in keeping with the area and the unit will block the views of local residents. The horsebox has now been replaced with a catering pod, details of which have been provided to all responsible authorities and objectors.
28. Following the consultation, the applicant was provided with a copy of the redacted representations to which she provided a response. This at her request was forwarded to all of the objectors. A copy of her response can be found at Appendix 5.
29. Details of the specific concerns raised by the objectors were also sent to the Environmental Health department and Island Roads. Officers from these services are qualified to assess the likelihood of the concerns raised and the impact of any of such outcomes.
30. Further comments from a Senior Environmental Health Practitioner can be found at Appendix 6.
31. Contact was also made with the Isle of Wight Council's Service Manager for Climate and Environment in order to obtain his views regarding the concerns raised around the environmental impact of the generator. Details of the generator provided by the applicant were sent to him and in response he stated that:

“The Isle of Wight Council advocates the use of renewable sources of energy where it is safe and practicable to do so over fossil fuel generators, we would encourage business to ensure that their environmental impact is reduced to so far is reasonably practicable, and look to use hybrid systems and the Best Available Technology (BAT) to reduce the environmental impact from their business.”

Financial/Budget Implications

32. Broadly, Council expenditure on licensing matters, and specifically those administered and enforced through licensing, balances income generated from fees.

Legal Implications

33. The primary legislation in relation to street trading is Schedule 4 of Part III of the Local Government (Miscellaneous Provisions) Act 1982 (the Act).
34. Section 2 of Schedule 4 to the Act provides for a council to designate any street as a) a prohibited street; b) a licence street or c) a consent street.
35. On 20 April 2004 the Isle of Wight Council resolved that for the purposes of street trading all current and future streets, council car parks, recreation grounds and open spaces along with public parks, gardens, amenity areas, sports areas and parking bays adopted by the council in the Isle of Wight be adopted as “consent streets” with effect from 28 May 2004.

36. Paragraph 7(2): Subject to paragraph (3) below, the council may grant a consent if they see fit.
37. Paragraph 7(4): when granting or renewing a street trading consent, the council may attach such conditions to it as they consider reasonably necessary.
38. Paragraph 7(5): Without prejudice to the generality of sub-paragraph (4) above, the conditions that may be attached to a street trading consent by virtue of that sub-paragraph include conditions to prevent obstruction of the street or danger to persons using it; or nuisance or annoyance (whether to persons using the street or otherwise).
39. Paragraph 7(8): The council may include in a street trading consent permission for its holder to trade in a consent street from a stationary van, cart, barrow or other vehicle, or from a portable stall.
40. Paragraph 7(9): If they include such a permission, they may make the consent subject to conditions as to where the holder of a street trading consent may trade by virtue of the permission; and as to the times between which or periods for which he may so trade.
41. Paragraph 7(10): A street trading consent may be granted for any period not exceeding 12 months but may be revoked at any time.
42. Local opposition or support (in whatever form) for a proposal is not in itself grounds for refusing or granting a licensing permission, unless that opposition or support is based upon valid reasons and concerns, which can be sustained.
43. There is no right of appeal against the refusal to grant a consent or against the revocation or variation of a consent.

Implications under the Crime and Disorder Act 1998

44. Members are advised that without prejudice to any other obligation imposed on it, it shall be the duty of each authority to which this section applies to exercise its functions with due regard to the likely effect of the exercise of those functions on, and the need to do all that it reasonably can to prevent, crime and disorder in its area.

Human Rights

45. Members are advised that this application must be considered against the background of the implications of the Human Rights Act 1998.
46. It is considered that there is one convention right, which needs to be considered in this context:

Article 6 - Right to a Fair Trial

47. In the determination of his civil rights and obligations, or of any criminal charge against him, everyone is entitled to a fair and public hearing within a reasonable time by an independent and impartial tribunal established by law.
48. It has been held that any person aggrieved by a decision of the licensing committee in relation to street trading has the right to challenge that decision in the High Court by way of judicial review.

49. The Licensing Authority acknowledges the right of businesses in its area to operate, but equally acknowledges the fact that this must be balanced against the rights of residents not to be disturbed by unreasonable noise and nuisance caused by licensed premises. The Sub-Committee needs to be clear as to the rights granted and the need to ensure that the reasons given for any interference are proportionate and in accordance with the Council's legitimate aim.

Equality and Diversity

50. There is no requirement for an equality impact assessment to be carried out.

Options

Option 1: To grant a street trading consent in accordance with the application and subject to the standard conditions.

Option 2: To grant a street trading consent in accordance with the application and subject to the standard conditions, and subject to any further conditions the Sub Committee deem necessary.

Option 3: To grant a street trading consent in accordance with Option 1 or 2 for a period of up to twelve months.

Option 4: To grant a street trading consent in accordance with Option 3 with the option to extend to twelve months, following a review of the trial period.

Option 5: To refuse to grant a street trading consent.

Risk Management

51. With regard to Options 1 - 4: Should the street trading consent be granted, the concerns raised by objectors to this application may not be addressed. The objectors will have no right of appeal. However, the Council could be challenged by way of judicial review.

52. With regards to Option 5: Should the Committee refuse to grant a street trading consent, Ms Sykes will be unable to trade. She has no right of appeal against this decision but could challenge the decision by way of judicial review.

Evaluation

53. In making its decision, the Licensing Sub-Committee should have regard to the Isle of Wight Council's Street Trading Policy 2022 – 2024.

54. Under the policy 'need' and 'competition' are not factors to be considered when determining street trading applications. The committee should assess the impact of the grant of this application when making its decision on:

- Public Safety/Protection of Children from Harm
- Prevention of Crime and Disorder
- Prevention of Public Nuisance
- Visual Impact

55. There has been a number of representations that have referenced competition and the issue of need, along with other matters that cannot be considered in line with the policy. These comments have been redacted from the representations and members should be mindful that these matters cannot be referred to during the hearing or considered when determining this application.

56. In respect of the concerns that have been raised with regards to the generator, specifically in respect of fumes, the applicant has provided further details in her submissions. She states:

*“Dual fuel Generators are more environmentally friendly than standard generators which run on either gasoline or diesel.
Dual fuel Generators have a highly efficient engine and use cleaner propane reducing toxic gas emissions.
This generator will run off the lpg 98 % of the time, leading to a much cleaner environment ,as an example you often see these generators used on coffee bikes.”*

57. In respect of noise she states:

“Most generators come as standard as 75 decibels upwards, our Generator comes in at just 58 decibels ,this is well below the standard. As an example this produces the same level of noise as a conversation. Another example is that standard Mr whippy machine creates 70 decibels upwards, again the generator coming in under this level.”

58. The applicant has also confirmed that the generator –

“will be encased in a weather proof case suitable for when in use and also creates another sound barrier,as stated by Island roads ,the location its 50 metres away for nearest properties and with being encased and on the other side of the pod it will also act as a shield, it will not disturb any residents.”

59. A Senior Environmental Health Practitioner has carried out a site visit and assessed the location and the specifications of the generator in relation to noise, fumes, safety, control of noise at work and vibrations. His report can be found at Appendix 6.

60. The Isle of Wight Council's Service Manager for Climate and Environment has confirmed that -

*“They are using the *BAT with the use of a low emission generator, and they are looking to get solar panels in the future which shows a commitment to going carbon neutral in the future, which is what we are looking for as a LA.”
* best available technology*

61. In respect of the concerns that have been raised regarding road safety around children wandering off to buy beach items, crossing the road on a bend and congestion of the pavement if there is a queue of customers waiting to be served; these concerns can no more be attributed to this trader than any other.

62. The responsibility of ensuring the safety of a child sits with the parents or carers. The hazards of water, a road and venues selling items that are

appealing to children already exist in this location and therefore pose no further or greater risk.

63. Congestion of the pavement is a factor that Island Roads officers will have considered when granting permission for trading to take place. The Streetworks Manager for Island Roads states –

“The footway is more than wide enough for people to be waiting to make a purchase and still have space for others to freely pass by – I would estimate the footway being 4 metres wide.”

64. The Streetworks Manager will endeavour to attend the hearing to answer any questions that members may have.

65. In respect of crime and disorder and the concerns raised that if this is a permanent overnight fixture that it will attract a criminal element to the area, the applicant requests permission to trade until 5pm Monday to Saturday, and until 4pm on a Sunday. The unit will be removed each day and therefore there is no risk in this regard.

66. In respect of public nuisance – concerns regarding the use of the generator have already been addressed at paragraphs 55 – 60.

67. Regarding litter - conditions placed on all street trading consents require traders to keep, maintain and leave their trading locations in a clean and tidy location. Conditions also require that any waste arising from the activities of the consent holder shall be removed from the site on a daily basis and disposed of in an approved manner. A copy of the standard static street trading conditions can be found at Appendix 8.

68. The applicant has also confirmed that she will be providing a litter bin and will be carrying out spot checks throughout the day as well as providing a choice of edible ice cream tubs.

69. It should also be noted that no trader can be held responsible for the actions of any individual who is accountable in their own right if they choose to engage in anti-social behaviour by discarding litter.

70. With regards to the concerns raised around the discharging of waste water into the sea, the applicant has confirmed that the only waste water will be from the sink which will be taken home and emptied each night.

71. Finally in respect of nuisance, concerns raised that the grant of this consent may lead to an increase in illegal parking or the blocking of resident's driveways - as with the issue of littering, no trader can be held responsible for the actions of another.

72. Island Roads on behalf of the highways authority as the landowner have granted permission for this trader to trade in the location requested. They grant permission as they see fit and will do so based on their own determination criteria.

73. In respect of visual impact – concerns were initially raised that a converted horsebox was not in keeping with the area and the unit will block the views of

local residents. The horsebox has now been replaced with a catering pod, details of which have been provided to all responsible authorities and objectors.

74. The proposed trading location does not impede any resident's view of the Solent as it is proposed to be sited opposite an unoccupied area of woodland.

75. The pod itself is in very good condition and in terms of visual impact is not considered in any way to be a negative addition to the seafront.

76. If a consent is granted and the conditions are breached, or if there were to be substantiated issues of concern connected to any aspect of trading, then the legislation allows officers to vary the conditions or revoke the consent at any time.

Recommendation

Option 1: To grant a street trading consent in accordance with the application and subject to the standard conditions.

Appendices Attached

Appendix 1	Application for a Street Trading Consent
Appendix 2	Plan showing proposed trading location
Appendix 3	Picture and dimensions of catering pod
Appendix 4	Redacted representations
Appendix 5	Applicant's response to representations
Appendix 6	Report from Senior Environmental Health Practitioner
Appendix 7	Street trading conditions

Background Papers

- Isle of Wight Council Street Trading Policy
<https://iwc.iow.gov.uk/documentlibrary/download/iwc-street-trading-policy-13-1-2022>

Contact Point: Ms Andrea Bull, Assistant Licensing Manager, ☎ 823159 ext 6126 e-mail Andrea.bull@iow.gov.uk

This page is intentionally left blank

Static trader application

A static trader operates from specific locations that are applied for. They are only permitted to trade during the times and in the locations stated in the consent.

Is this an application for the grant of a new consent or renewal of an existing consent?

Grant

Renewal

If you have an existing consent number, please write it here

[Empty text box]

Trader details

Trading name

The salty Siren

Full name of applicant (including title)

Carly Sykes

Date of birth

[Redacted]

Address of applicant

Alternative address for correspondence

[Redacted]

[Empty text box]

Telephone number

[Redacted]

Email address (optional)

[Redacted]

National Insurance Number

[Redacted]

Are you VAT registered?

Yes No

Registration number

[Empty text box]

Name of any employees or persons who may assist you in your trading

lindy murray/bussiness partner

Have you registered with the Isle of Wight Council as a food business?

Yes No Not applicable

Trading details

List of items to be sold

Ice creams, lollies, water, cans
coffee, pre packaged bakes, slushy, popcorn
tea, crisps, buckets, spades, beach shoes, litte crabing nets

Details of any equipment to be used (including generators/fryers etc).

generator, freezer, coffee machine, urn, slushy machine, fridge

Proposed duration of consent: One day One week Two weeks One month
 Three months Six months Nine months One year

Please specify start and end date(s)

20th may 2024 /20th may 2025

Please state if you wish to remain in one location while trading, but propose different locations to be considered during consultation in case your first choice is objected to.

Days	✓	Start time	End time	Preferred location	Alternative location
Monday	✓	9 am	5pm	princes esplanade	further along princes esp
Tuesday	✓	9am	5pm	princes esplanade	further along princes es
Wednesday	✓	9am	5pm	princes esplanade	further along princes esp
Thursday	✓	9am	5pm	princes esplanade	further along princes esp
Friday	✓	9am	5pm	princes esplanade	further along princes esp
Saturday	✓	9am	5pm	princes esplanade	further along princes esp
Sunday	✓	10 am	4pm	princes esplanade	further along princes esp

Vehicle details

Reg. Make Model
 Length Width Height

I understand that I must now advertise my application in the Isle of Wight County Press (within the first ten working days of submitting the application), and at the premises for the duration of the 21 day consultation period. Failing to comply with this requirement (as outlined in the Isle of Wight Council's policy) will render the application invalid. An advertisement template is available from the licensing section.

This is not necessary if the application is for a renewal unless there are changes from the previous consent and the licensing section deem it necessary to treat the application as if it was a new application.

This authority is under a duty to protect the public funds it administers, and may use the information you have

This application must be accompanied by (please tick):

- at least 25% of the full fee;
- plans/maps showing the exact proposed locations and the proximity to nearby retail premises including those that sell the same or similar goods;
- photographs of the front and side of the vehicle/stall to be used for trading activities;

provided on this form for the prevention and detection of fraud. It may also share this information with other bodies responsible for auditing or administering public funds for these purposes.

For further information, see www.iwight.com/nfi to view the Level 2 notice.

I wish to apply for a street trading consent to operate as a static trader. I declare that I have checked the information given on this application form and to the best of my knowledge and belief it is correct. I understand that a false or misleading statement, or that withholding relevant information, may result in the refusal or revocation of the consent and/or may render me liable to prosecution.

- proof of public liability insurance (minimum £10,000,000);
- permission from the landowner to use the land any proposed location;
- confirmation from the planning department as to whether or not permission from them is required.

Signed

Date

Licensing Section High Street, Newport, Isle of Wight, PO30 1UD
 Tel. 01983 8 ing@iow.gov.uk

The Isle of Wight Council is the data controller for the personal information you provide on this form. The council's data protection officer can be contacted at dpo@iow.gov.uk. You can contact the council by phone on 01983 821000, or by writing to us at County Hall, High Street, Newport, IW PO30 1UD.

For office use only	Receipt number	Page 20	Reference number
---------------------	----------------	---------	------------------



Sea View Shelter

Egypt

2nd choice

Plaza Ice-cream
Van View Point
Ice Cream

1st choice

Prince's Esplanade

This page is intentionally left blank

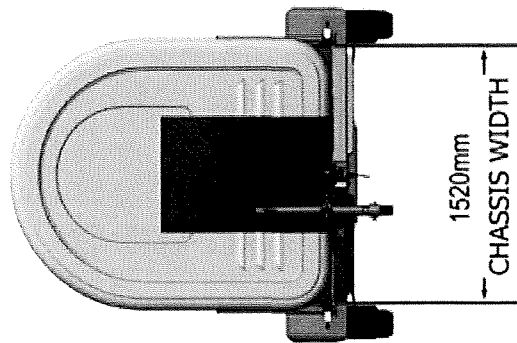
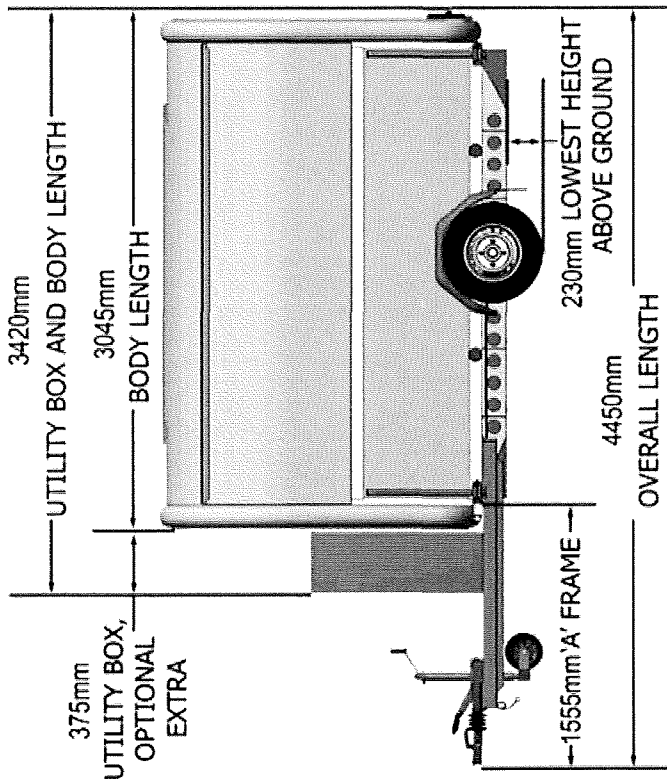
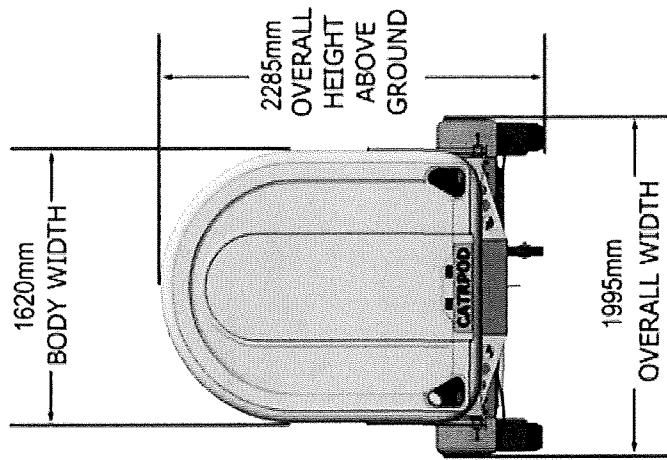



Mr Gary Hall

[Redacted]

Comments Submitted Via Email

Dear Sir / Madam,

I would like to make my representation to be considered on the above new Street Trading Application (24/00055) at Princes Esplanade Gurnard Isle of Wight.

[Redacted]

The new application is for a converted Horse Box with the equipment ran by a generator typically producing both noise and fumes. This goes against the IWC Street Trading policy 2022 where it states new applications should consider using 100% electric or green powered vehicles and equipment.

[Redacted]

For the abundance of reasons above and likely impact of the proposed trading I would like to object on the following grounds -

PUBLIC SAFETY -

The parking up of the horsebox, along with the towing vehicle represents a hazard to the public on a daily basis.

The noise of the generator represents a hazard and spoilage of a seafront walk on a daily basis.

The fumes of a generator represent a hazard and spoilage of a sea front walk on a daily basis.

Refilling of a generator with fuel poses a risk to public / staff.

PUBLIC NUISANCE -

The parking up of the horsebox, along with the towing vehicle represents a nuisance to the public by taking up limited parking space especially in high season.

The noise of the generator represents a public nuisance and hampers enjoyment of the area. This is of particular nuisance in busy weeks and to the local to residents living near location 1.

The fumes / odour of a generator represents a nuisance to both public and wildlife.

[REDACTED]

THE VISUAL IMPACT -

The pictures supplied show a converted horsebox. it is not in keeping with the amenity and character of the area. It is more suited to a country show / countryside. You have got to ask yourself how many horses have urinated in that horsebox previously and is it an asset to our beautiful seafront?

[REDACTED]

[REDACTED]

Kind regards

[REDACTED]

[REDACTED]

Mrs Claire Holley

[REDACTED]

[REDACTED]

[REDACTED] This will be a safety issue for families - children wandering off to buy beach items. Also the trailer will be selling items which inevitably will end up as beach litter or in the sea (buckets/spades/crabbing hooks etc). The other traders are very eco with their use of green power, this should be encouraged.

Ian & Anne Dickens

[REDACTED]

We notice the signage attached to the railings on Princes Esplanade regarding an application for a trader to use a mobile horse box to offer ice creams, beverages, snack foods and beach paraphernalia.

We'd like to make the following observations:

- [REDACTED]
- [REDACTED]
- [REDACTED]
- The addition of pre-packed food, pop corn and crisps present a litter issue.
- [REDACTED]

[REDACTED]

[REDACTED]

[REDACTED]

[REDACTED]

[REDACTED]

[REDACTED] The sight of an ice cream van is a traditional part of a seaside scene while a converted horse box less so.

[REDACTED] an additional trader that will take up a parking space - premium in the summer months [REDACTED]

[REDACTED]

[REDACTED]

[REDACTED]

[REDACTED]

[REDACTED]

[REDACTED]

[REDACTED]

Marguerita Teague

[REDACTED]

[REDACTED]

[REDACTED]

In response to licensing Application 24/00055/STSTAN

This is not the right location for this application for the following reasons:

1. Visual Impact

20 yards is too close to Solent Shores residential flats and will have an impact. It is only 15 yds yards from the front of my garden at Apartment 1, clearly visible where I see from (but my garden cannot easily be seen from the road). The Apartments and Houses are owner occupied and fully residential in the summer. They are right on the road with balconies on all sides and wide opening doors and windows, to the side and front and this proposal will be in full view from all our windows and balconies and living areas at this end and probably further down too.

2. Congestion and Public Safety.

There is no "Apron" set back from the pavement at this site, which makes it even more unsuitably placed. The pavement is only really wide enough for 2 couples to pass each other and there is no space or seats around to rest or take a break. Trading posts naturally collect people around them, queuing for ice creams, coffee etc. This is evident around all the others, Plaza Ices, the Coffee Stall and Dave's Locker all of which have these Apron areas to absorb the customers.

There can be a lot of congestion opposite Solent Shores, particularly at summer weekends - with lots of cars and large vans, filled with kit, parking up. Even on a normal day in fine weather and particularly in high summer when numbers increase, we have walkers, runners, little kids on mini scooters and bikes, Mums with buggies, dogs on leads, and it is not even always easy to pass people walking in both directions on a pavement which can just take 2 couples. Then you have families, several walking abreast, groups of teenagers, elderly couples needing space and swimmers and paddle boarders using the steps, Car Doors get opened and closed

on both sides and car boots opened and shut to offload kit, even sometimes deck chairs on the pavement! And since lockdown and the rise in AirBnB we are seeing many more visitors.

Add to this a Trading post in horse box 5.45 metres x 2.5, (but how wide?) which may seem great - but the result will be walkers etc heading out into the road to avoid the pavement with the inevitable queue and people lingering, and this will likely lead to a serious public safety issue or accident to children as cars whizz along here sometimes and there are added bikes and scooters on the road.

In addition the pavement on the opposite side runs out at my garden boundary, almost opposite the proposed site and everyone on this side either has to cross over onto the pavement past the the proposed Trading Post or walk on the road.

[REDACTED]

Solent Shores applied for the yellow lines on this side precisely because of a safety issue and not being able to see round traffic and not being able to see round the cars. [REDACTED]

[REDACTED]

3. Litter

Selling packeted food, plastic, water + popcorn and crisps etc inevitably creates litter. We are always short on litter bins along here, they get washed away in the storms and new ones have to be ordered and installed. Never enough. When they spill over the foxes love them and this is quite apart from the possibility of other vermin and wildlife from the wild land opposite if food like popcorn and drink items get spilt. Plastic and crisp packets can also blow around onto the land opposite which cannot be accessed and can blow into the sea. [REDACTED]

[REDACTED]

4. Public Nuisance.

I see in the application that a Generator will be employed to run the freezers etc. all day. Generators are noisy. They run on diesel or petrol and give off fumes.

I am extremely concerned about this last point as it would prevent me from the right to enjoy my own garden and living area as I have chronic respiratory sensitivity to these pollutants and have had on occasions to shut windows when cars are left idling in the warm weather. This is why some of us choose to be beside the sea.

Having a Generator running nearby with the wind blowing in this direction in order to facilitate a trading post is not acceptable from both the the noise and the pollution to all of the homes (balconies etc) at Solent Shores again make this an unsuitable location.

[REDACTED]

Conclusion

This is not a suitable location for this Trading Post because :

- 1. Too close to Solent Shores, including visual impact abundance all the following:
- 2. No "Apron" to take up the pedestrian congestion on pavement
- 3. Safety issues around the road
- 4. Prevention of litter and vermin near homes.
- 5. Public nuisance from the noise and Pollution from Generator.

[REDACTED]

[REDACTED]

[REDACTED]

[REDACTED]

[REDACTED]

[REDACTED]

[REDACTED]

Mr Adam Stafford

[REDACTED]

[REDACTED]

I am resident at Solent Shores which is neighbouring this proposed site. I would strongly object to the more westerly location (Option 1) on the grounds of noise nuisance and safety.

Safety: Children crossing the road to reach the location in Option 1, the more westerly option, would be crossing near a blind bend which is very unsafe.

Nuisance: The location proposed in Option 1 is just yards from the gardens and balconies of the Solent Shores apartments and would be a noise nuisance and blight the view. This would be of significant detriment to all residents.

Mathew J Hannaby

[REDACTED]

[REDACTED]

[REDACTED]

Ref: Licensing Application 24/00055/STSTAN Street Trading Static New Land At Princes Esplanade Gurnard Isle Of Wight

To whom it may concern,

As a neighboring resident to the proposed plan, I would like to formally OPPOSE the approval of this application based on the following points:

- 1. No thoughtful investigation into the local community: The noise pollution emanating from a sited vehicle, powered by generators, would be detrimental to the local red squirrels, avifauna, and bats.

[REDACTED]

[REDACTED]

[REDACTED]

3. Absence of forethought into the environmental impact of littering: The sale of pre-packaged produce could lead to littering, with no clear plan to mitigate its environmental impact.

4. Excessive pollution from engine waste: The use of generators to power this unit would contribute to excessive pollution, further harming the local environment.

[REDACTED]

[REDACTED]

Sincerely,
Mathew J Hannaby

Mrs Suzanne Hannaby

[REDACTED]

Comments Submitted Online

My children and I have hidden disabilities and the impact of a generator, smell, noise and vibrations has an impact to our safety. Being so close to our home we will have a detrimental effect on our quality of life. Sensory impact on neurodiverse individuals -residents and visitors - in this quiet calm place needs to be assessed as part of this process. The application suggests a permanent fixture and this will bring a criminal element to the area which is dark and unlit at night. As a woman i can safely walk along the esplanade at night but this would deter me and I am afraid for my safety. During the day queues of people, children and dogs would be concentrated in an area with limited passing, no opposite curb and a busy road. Safety to the public will be affected by this facility. [REDACTED]

[REDACTED] the wildlife will be impacted by the rubbish and the nuisance to swimmers of this facility will be huge.

Comments Submitted Via Email

24/00055/STSTAN

Street Trading Static New

Land At Princes Esplanade Gurnard Isle of Wight

To Whom It May Concern:

1a) as a resident with neurodiversity and with children with neurodiversity I can see no consideration for the public nuisance caused by the noise of the generator to myself and family. The impact of low noise and vibration to a neurodiverse person is felt at levels that neurotypical people cannot understand. In selecting to live on the esplanade in a quiet area surrounded by natural and none invasive noise I would want any planning/licensing decision to take my disability into consideration before progressing. Has this assessment been carried out? This is part of the disability act and all planning should take this into consideration.

1) The application says that the applicant will be using a generator to use for the fridge, freezer, coffee machine, urn and slush machine. Having read the guidelines by the

Occupational Safety and Health Administration, I am quite concerned for the following reasons:

- a. It does state that generators should not be used in a work environment as they vibrate and create noise and if it is a necessity to do so, then hearing protection must be worn.
 - i. The vibrations and noise pollution will affect the employees working there, the general public walking past and the local residents. It will especially affect visitors and residents who are neurodiverse and who use the quiet of this environment to manage stress levels. This is a level of noise pollution that is being underestimated and people with hidden disability are being ignored.
 - b. The guidelines say not to use a generator in rain or wet conditions, it needs to stay dry at all times. Surely this means that a generator can not be used in the position that is being requested as it will be about 2 mtrs from the sea and during high tides and certain weather conditions the sea comes over the sea wall and floods the road. The risk of public nuisance from chemicals leaking from a flooded generator or vehicle will cause damage to public foot paths and wildlife.
 - c. The application says static, does this mean that the street trading vehicle will be on the street 24 hours a day? The application is asking for 7 days a week, 12 months a year. Does this mean that the generator will be on for 24 hours a day, every day? If so, where will the protection be against the generator getting wet and what about the noise nuisance. This area has no streetlights and so is very quiet at night as it isn't used by many pedestrians and the vibration and noise caused by a generator will surely be classed as noise pollution and may affect the quality of the life of all local residents close to the vehicle in question, not only during the day but also through the night. When considered through the lens of a neurodiverse person this level of noise pollution will affect quality of life.
 - d. As the generator will produce fumes this will not be a pleasant environment for walkers or local residents. When considered in terms of neurodiversity the smell of fumes will have a negative impact on people with disability. This can cause headaches and nausea even at small levels. I struggle with the car fumes on a busy summer's day and the council have done a great job limiting the parking in this area which helps. But a generator permanently running will impact quality of living for residents and visitors who are neurodiverse.
 - e. If the generator is left unattended, this will cause a concern over public safety, both during the day and at night.
- 2) Regarding crime, if this is static and left unattended, this could encourage youths to commit crimes. They will know that there will be items left on the vehicle and may try to break into it to retrieve them. Generators are costly, it is not unknown for them to be stolen.
- 3) If I have misunderstood that static means permanent, then will the vehicle be removed at the end of each day?
- a. What happens if other vehicles have parked in their designated space whilst they are away, what happens to the vehicle then?
 - i. Will it be moved along and parked outside the residential area? This will cause the local residents to have to live with the nuisance of the noise and fumes from the generator all day.

[REDACTED]

[REDACTED]

[REDACTED]

[REDACTED]

[REDACTED]

[REDACTED]

- 5) As the vehicle will be positioned right next to the pavement, should there be a queue waiting for drinks to be made, this may inhibit people passing which will include:
 - a. Groups of people, which is very common during the summertime
 - b. Most of the pavement along the esplanade is quite slopped and as this is the flattest part of the esplanade will often be used by wheelchair users
 - c. People with pushchairs
 - d. People with young children on little bikes or scooters
 - e. Dog walkers
 - f. Will the hindered pedestrians try to walk around the vehicle causing road safety concerns? Unfortunately, people today are not used to waiting, having no pavement on the opposite side of the road to cross to may prove to be quite dangerous.
 - g. The reduction in parking and yellow lines on one side of the esplanade in order to protect pedestrians seems to be negated with this application and will simply cause a public nuisance with the potential for accidents.
- 6) There is already pressure on the number of parking spaces on the esplanade during the height of the season, this currently leads to some people parking in private resident spaces already causing nuisance and conflict. This vehicle together with its generator is likely to take up to 2 spaces which will exacerbate the parking.
- 7) The application says that some of the items to be sold is going to include popcorn, crisps and baked goods. This is also concerning as small children will spill their popcorn and crisps as they walk leaving behind a trail of food, this could be eaten by dogs, it could attract seagulls and even worse it could create a problem for local residents if they get a vermin infestation.
- 8) Should children drop their litter and not be noticed by supervising adults, then this could get blown into the sea and could cause problems for the wildlife living in the sea, not good for the marine environment.

[REDACTED]

[REDACTED]

[REDACTED]

[REDACTED]

[REDACTED]

Conclusion:

It is going to be a nuisance with loud noise and vibrations from the generator, fumes released into the prevailing winds, hazardous due to the wet conditions you get being by the side of the sea. The specific impact on neurodiverse individuals has not been considered or any way to mitigate against the noise, smell and vibration proposed. This is discriminatory and should be considered under the planning and disability act. Public nuisance to a neurotypical person is not the same as for a neurodiverse person and I have been excluded in this application.

If left overnight this will disturb local residents trying to sleep and may encourage crime.

The location is too close to the sea and too close to a normally very quiet residential area.

[REDACTED]

Queues could be very hazardous to people passing, which may cause safely issues. Spilled food can cause harm to local wild life and may cause a vermin infestation for local residents, especially be sited opposite a woodland area full of natural habitat.

[REDACTED]

[REDACTED]

Peter & Catherine Critchley

[REDACTED]
[REDACTED]
[REDACTED]
[REDACTED]

Dear Licensing team / case officer Ms Andrea Bull,

With regard to the above Street Trading Static application (new) at land at Princess Esplanade, Gurnard, IOW. Applied for by Carly Sykes, The Salty Siren.

We would like to object to this application on the following grounds:

- * Public safety - increased risk for crossing on what is already a busy road and parked vehicles. Particularly relevant for a facility aimed at children.
- * Public Nuisance - noise, rubbish, smells including the increased risk of vermin. Blocking what is already a busy footpath with particular impact on users with mobility issues, wheelchairs, mobility scooters and pushchairs. Groups congregating and using the public footpath and sea wall as a cafe area.
- * Visual Impact - totally out of keeping with the protected nature area opposite the proposed site and in very close proximity to private housing. Inappropriate natural location for local people to enjoy the beautiful sea front.

Tracey Williams

[REDACTED]
[REDACTED]

Ref: Licensing Application 24/00055/STSTAN
Street Trading Static New
Land At Princes Esplanade Gurnard Isle Of Wight

To Whom It May Concern:

With reference to the above new trading application for a static street trading request, I would like to note my objection for the following reasons:

- 1) The application says that the applicant will be using a generator to use for the fridge, freezer, coffee machine, urn and slush machine. Having read the guidelines by the Occupational Safety and Health Administration, I am quite concerned for the following reasons:
 - a. It does state that generators should not be used in a work environment as they vibrate and create noise and if it is a necessity to do so, then hearing protection must be worn.
 - i. The vibrations and noise pollution will affect the employees working there, the general public walking past and the local residents.
 - b. The guidelines say not to use a generator in rain or wet conditions, it needs to stay dry at all times. Surely this means that a generator can not be used in the position that is being requested as it will be about 2

mtrs from the sea and during high tides and certain weather conditions the sea comes over the sea wall and floods the road.

- c. The application says static, does this mean that the street trading vehicle will be on the street 24 hours a day? The application is asking for 7 days a week, 12 months a year. Does this mean that the generator will be on for 24 hours a day, every day? If so, where will the protection be against the generator getting wet and what about the noise nuisance. This area has no streetlights and so is very quiet at night as it isn't used by many pedestrians and the vibration and noise caused by a generator will surely be classed as noise pollution and may affect the quality of the life of all local residents close to the vehicle in question, not only during the day but also through the night.
 - d. As the generator will produce fumes this will not be a pleasant environment for walkers or local residents.
 - e. If the generator is left unattended, this will cause a concern over public safety, both during the day and at night.
- 2) Regarding crime, if this is static and left unattended, this could encourage youths to commit crimes. They will know that there will be items left on the vehicle and may try to break into it to retrieve them. Generators are costly, it is not unknown for them to be stolen.
- 3) If I have misunderstood that static means permanent, then will the vehicle be removed at the end of each day?
- a. What happens if other vehicles have parked in their designated space whilst they are away, what happens to the vehicle then?
 - i. Will it be moved along and parked outside the residential area? This will cause the local residents to have to live with the nuisance of the noise and fumes from the generator all day.
- [REDACTED]
- [REDACTED]
- [REDACTED]
- [REDACTED]
- [REDACTED]
- [REDACTED]
- [REDACTED]
- [REDACTED]
- [REDACTED]
- [REDACTED]
- [REDACTED]
- 5) As the vehicle will be positioned right next to the pavement, should there be a queue waiting for drinks to be made, this may inhibit people passing which will include:
- a. Groups of people, which is very common during the summertime
 - b. Most of the pavement along the esplanade is quite sloped and as this is the flattest part of the esplanade will often be used by wheelchair users
 - c. People with pushchairs
 - d. People with young children on little bikes or scooters
 - e. Dog walkers
 - f. Will the hindered pedestrians try to walk around the vehicle causing road safety concerns? Unfortunately, people today are not used to waiting, having no pavement on the opposite side of the road to cross to may prove to be quite dangerous.
- 6) There is already pressure on the number of parking spaces on the esplanade during the height of the season, this currently leads to some people parking in private resident spaces already causing nuisance and conflict. This vehicle

together with its generator is likely to take up to 2 spaces which will exacerbate the parking.

- 7) The application says that some of the items to be sold is going to include popcorn, crisps and baked goods. This is also concerning as small children will spill their popcorn and crisps as they walk leaving behind a trail of food, this could be eaten by dogs, it could attract seagulls and even worse it could create a problem for local residents if they get a vermin infestation.
- 8) Should children drop their litter and not be noticed by supervising adults, then this could get blown into the sea and could cause problems for the wildlife living in the sea, not good for the marine environment.

[REDACTED]

[REDACTED]

Conclusion:

It is going to be a nuisance with loud noise and vibrations from the generator, fumes released into the prevailing winds, hazardous due to the wet conditions you get being by the side of the sea. If left overnight this will disturb local residents trying to sleep and may encourage crime.

The location is too close to the sea and too close to a normally very quiet residential area.

[REDACTED]

Queues could be very hazardous to people passing, which may cause safety issues. Spilled food can cause harm to local wild life and may cause a vermin infestation for local residents, especially be sited opposite a woodland area full of natural habitat.

Dr Alison Hutton

[REDACTED]

[REDACTED]

The proposed position will block several parking areas which may cause poor parking (eg on double yellows, blocking driveways) in the height of the summer. People gathering on the pavement will prevent other people walking along the Esplanade, these people may choose to walk in the road and as there is no pavement on the opposite side of the road this would not be safe. There is a risk of littering from the wrappings of the food for sale. [REDACTED]

[REDACTED]

[REDACTED]

Mrs Helen White

[REDACTED]

[REDACTED]

I feel a trader in this location would be a public nuisance if a generator is in situ, not only because of the noise but also the fumes expelled. This Esplanade is enjoyed by many including the elderly, disabled and families . Any type of premises/stall could prove to be a dangerous obstacle and may increase the amount of rubbish left by users.

Antony Dudley

[REDACTED]
[REDACTED]
To Whom it May concern

Re: Street Trading Static new land at Princes Esplanade, Gurnard, Isle of Wight Ref 24/00055/STSTAN

With reference to the above Application, please find below my objections for the proposal.

The Visual Impact

The site being proposed for use is on a road, sandwiched between the Solent seashore and a Conservation Area (which is protected). The Esplanade frequently suffers from the effects of strong Easterly and Westerly winds, with litter being swept along the seafront, or into the sea or the Conservation Area. Added to this, with big tides and swells, the sea frequently tops over the road and has, in the last 6 months, swept at least 2 Council bins for public use, off their stand and along the road. There is already insufficient bins for public use, so a Static van producing a lot more refuse would be detrimental to the immediate surroundings. Also, on windy days (quite often), one bit of litter dropped by mistake would be blown down the seafront before the owner could retrieve it. This would be an eyesore if litter were to get stuck in the Conservation Area, and damaging to sea life in the other direction. [REDACTED]

[REDACTED]
[REDACTED]
[REDACTED]
[REDACTED]

Prevention of Public Nuisance

As I read it, there will be a generator running 24/7? As the proposed site is close to the Gurnard residential area, this will have a huge impact on noise levels, particularly during Easterly winds. This road has no street lighting and does not have a high level of traffic during the night, so is therefore a quiet road with minimal noise. A noisy generator running 24/7 would cause a lot of noise pollution. The majority of Residents along this stretch of The Esplanade, are of retirement age, and enjoy the peace and quiet during the evenings. My understanding is that a generator vibrates and creates noise, with the recommendation that persons using generators should wear noise defenders. This will surely affect the local residents as well as passers-by? Also it is recommended that a generator is kept away from wet weather, so is it proposed that this particular generator will be kept in a housing unit? Another concern is that when the sea, in high wind and weather conditions, tops the road, the generator would get very wet. On January the 4th we experienced a tidal surge resulting in the road becoming impassable at the very point where the site is proposed. In my mind there is no doubt at all that on this day the unit, generator & all & sundry would have been swept away towards Cowes damaging anything in its path along with the fact it would have then caused an obstruction when it finally came to its resting place. More detrimental effect to seafront railings, property, cars etc. Totally unacceptable.

Public Safety

Princes Esplanade has a higher volume of traffic during the Summer days, and cars park from Gurnard all the way to Cowes. I am sure the proposed Static van would attract more attention, which in turn would affect the wildlife in the Conservation Area, with increased exhaust fumes and noise. Footfall along the seafront would increase, I am also concerned that if there are a lot of people waiting for service at this site, would passers-by be forced to walk on the road to get past? This is not an ideal situation for children walking or on their bikes. The path is wider than your average pathway, so 4 people could walk side by side, but add in a 2-person queue, and already passing space is minimal.

Cars tend to speed up once they have cleared Solent Shores, the last development on the seafront, so would be increasing speed just as they reach the proposed site. Again, a hazard for pedestrians and drivers slowed down looking for parking spaces. Does this. Concession given by the council warrant such a risk to public safety. Would this arise itself in possible protracted Court cases bought by the public injured or worse killed due to this?

Prevention of Crime and Disorder

If the proposed static is to be left on this site 24/7, I assume it will be unattended during the non-trading night hours? As already stated this road between Gurnard and Cowes has no street lights. An unattended vehicle, with goods known to be inside, would surely attract unwanted interest? And potential crime attempts? Particularly a costly item such as a generator. With no street lights, this could also attract unwanted interest in property close by. I wonder what the local constabulary would think about this generator being left unattended. [REDACTED]

[REDACTED]

[REDACTED]

Protection of Children from harm

The increased volume of footfall and traffic is concerning, as Children use the seafront to ride their bikes, scooters etc. If the footpath is busy, children (who often ride/scoot way ahead of their parents/minders, and don't always have road sense) may look for the easy option to traverse the crowds, and take their bike/scooter onto the road, which would have to be between parked cars. This could have disastrous, unthinkable outcomes. Once again does this place the council in breach of its public Safety orders?? Only time will tell but is the risk worthwhile??

Louise Morton

A permanent static van in this position is completely inappropriate for a number of reasons.

1. The area opposite the proposed site is Green Belt/TPO, and it is not fitting to have a temporary structure parked opposite and so close to a residential area.

2. In 2024 it is totally unacceptable in a world that is generating too much carbon emissions and where the government is both legislating and encouraging reductions of carbon emissions which are clearly causing rising sea levels for Gurnard to have a generator running semi permanently throughout the year.

3. As we have seen regularly on a number of occasions this area is particularly exposed to westerly gales and often floods. It is inconceivable that during at least 3 or 4 of these storms this winter that a static van would survive the battering and salt water. Salt water is extremely corrosive and within no time at all it is highly likely that the appearance of this proposed van would deteriorate quickly creating an eyesore.

[REDACTED]

5. The development where my flat is requires pumping of all black and grey water and therefore any waste from this caravan can only be discharged into the sea - again totally unacceptable as there is already too much waste water and sewage being pumped into the system at Gurnard.

6. These outlets are notorious for creating rubbish and we need to preserve our beach and the Solent cannot tolerate yet more plastic from disposable cups etc being blown around.

[REDACTED]

Christopher & Emma Stevens

[REDACTED]

Dear Mr Winchcombe,

We would like to comment on the application for a street trading licence (24/00055/STSTAN) on Prince's Esplanade.

Attention should be given regarding the Isle of Wight Council's guidance on the prevention of nuisance, as it questions whether there will be substantial risk of nuisance due to noise and odour. There will be a generator running on site, which will cause both noise and odour nuisance, not only to the passing public in what is a very tranquil area, but also to residents of the flats some 60 metres away.

Attention should also be given to the visual impact, as it cannot be in keeping with the area as there is nothing else like it at present.

[REDACTED]

[REDACTED]

We hope you take these points into consideration when you are making your decision on whether to approve the licence or not.

We would be grateful if you could keep me informed with the application's progress.

David Jervis

[REDACTED]
[REDACTED]

To Whom It May Concern

I am writing on behalf of the Solent Shores Management Company for which I am a Director.

As you are aware Solent Shores comprises 13 properties fronting onto the Esplanade in Gurnard within very close proximity to the proposed static street trading license application.

The basis of the objection is as follows

Environmental pollution/ Noise pollution/ Nuisance/ Possible attraction for criminal activity/ Impact on pedestrian movement/ Impact on car parking

The application will attract litter in a sensitive location. We already suffer from overflowing bins in peak seasons often leading to rubbish being blown onto the beach and sea. It states that a generator will be used to power the static unit. This will create considerable noise pollution in what is a very tranquil location enjoyed not only by Solent Shores residents but many members of the general public walking along the Esplanade. It is not an appropriate location for a generator taking into account its close proximity to water and the general public. Concerns also include fumes generated and the possibility of attracting criminal activity if the generator is left unattended at night.

The proposed siting is on the narrowest part of the Esplanade. During peak times this part of the Esplanade is already congested.

There is already pressure on car parking in this area. Because of Highway Safety grounds car parking is already restricted to one side of the road. We already have instances of people illegally parking on double yellow lines and on people's private property. The possible siting of this static unit further exacerbates the problem.

I trust the above points will be taken into consideration and the application duly refused.

Yours faithfully

Elizabeth Neville

[Redacted]

Comments Submitted Online

I am mainly concerned that the proposed vehicle will run using a generator. These are extremely noisy and create air pollution. The pollution will have a detrimental affect on anyone in the vicinity including members of the public, local residents and employees along with the local wildlife, some of which is particularly sensitive to pollution.

The vehicle will be parked next to the pavement and any queue will be on the pavement. At peak times it is a very busy on this pavement and people could be forced into the road in order to pass the location of the proposed street trader. The road has a lot of traffic at these times and so the potential for accidents will be greatly increased. I am particularly concerned for the safety of young children.

There will inevitably be an increase in litter and food waste. [Redacted]

Comments Submitted Via Email

To Whom It May Concern:

I object to the above application for static street trading.

Noise and air pollution from the generator:

Generators produce a lot of noise and air pollution. The pollution will have a detrimental affect on anyone in the vicinity including members of the public, local residents and employees along with the local wildlife, some of which is particularly sensitive to pollution.

Outside peak times this is a very peaceful area and this peace will be spoilt with the noise of the generator.

I am concerned that the noise pollution from the generator will also continue outside the trading hours stated during set up and pack up time or worse still, permanently if the vehicle is left on the esplanade overnight.

Safety:

The vehicle will be parked next to the pavement and any queue will be on the pavement. At peak times it is a very busy on this pavement and people could be forced into the road in order to pass the location of the proposed street trader. The road has a lot of traffic at these times and so the potential for accidents will be greatly increased. I am particularly concerned for the safety of young children.

Litter and food waste:

It is almost certain that, with the type of food listed on the application, some of it will end up being accidentally dropped or discarded by customers. [Redacted]

[Redacted]

[REDACTED]

The inevitable increase in litter will add to the amount that is already polluting the sea and beaches.

Reduction in available parking:

At times there already isn't enough parking along the esplanade. The proposed vehicle will reduce the available parking even further. It is unclear if the length of the vehicle on the application form includes the generator.

Stuart Grundy

[REDACTED]

[REDACTED]

[REDACTED]

The generator proposal is of concern, I would like to understand the decibel's omitted, fuel type and omissions of the generator if it was to be located near to the seating locations as identified on the applicants plan.

Claire Sollis

[REDACTED]

Comments Submitted Via Email & Online

I would like to note my objection as, I believe, it will be a public nuisance. The points I list below:

1) The locations requested are both on the actual road and seafront which will cause congestion on the pavement and road, particularly at busy times, which will cause an obstacle for persons in a wheelchair or pushchair. [REDACTED]

[REDACTED]

2) The application states this is static so I assume that it will remain there 24 hours a day and if so, the generator will be required. If so, the generator will create noise (not declared) and I assume will run 24 hours a day - for an area of relatively tranquility that will be disruptive for those enjoying the seafront, day or night.

3) Increased litter will be created which will be a nuisance and unsightly for those that enjoy the seafront, including wildlife.

John Rosenthal

[Redacted]
[Redacted]
[Redacted]

Hi with reference to the application for a new Street trading license at Princes Green, Gurnard, IOW.

I can foresee with what will be 3 different vendors several queues of people, adults and children along the pavement, this is not really a problem but I feel that the issue of cyclist using the pavement becomes quite a safety issue.

[Redacted]
[Redacted]
[Redacted]
[Redacted]
[Redacted]
[Redacted]

[Redacted]
[Redacted]
[Redacted]
[Redacted]

[Redacted]

[Redacted]
[Redacted]

[Redacted]

Paul Fuller
Independent Isle of Wight Councillor for Cowes West and Gurnard.
Cowes Town Councillor, Gurnard Parish Councillor, Northwood Parish
Councillor

As Ward Councillor, I have continued to receive calls throughout the weekend concerning the Salty Siren application for Gurnard Seafront.

In essence, under licensing, most objections relate to concerns over the perceived noise and pollution from the generator, which will be required for the vehicle through its impact upon residential properties. To overcome this, the vehicle could be moved further east between dwellings impacted to address the noise/ pollution concerns.

In addition there are also concerns over the perceived permanency of the vehicle. To note, if it is not taken away from the location each evening, the vehicle could be damaged both through natural/ environmental processes, as well could become a target for anti social behaviour/ vandalism at night given the area has no street lighting.

To note, Princes Esplanade floods around 20 occasions each year, and should the vehicle be left unmanned overnight, I would have concerns over this.

The Salty Siren

To whom it may concern

In Regards to issues raised about my application I thought it might be helpful to send a bit more of a detailed plan that may help solve some of the issues and put people's minds at ease.

The design

The trailer is a caterpod, They are very lightweight and easy to manoeuvre both by hand and by car.

They are made with stainless steel worktops ensuring highest levels of hygiene.

Made from rust free material.

The pictures show exact pod with all dimensions



Please note the type of licence i have applied for is a static traders licence, this means i will be trading from one location ,the same each day but it does not mean the pod will be left overnight ,it will be taken to location each day .

Powering the Pod

We have thought long and hard about how to be as green as we possibly can when it comes to powering our pod.

Most of our equipment is self sufficient.

The urn will be gas powered

The ice machine and hot water sink run from their own batteries

The generator itself is there purely to run the fridge and freezer and will not pull a huge amount of power.

When it came to choosing the Generator we opted for a dual fuel inverter.

The pros to this type of power are as follows

Better Fuel Efficiency

They run on low fuel due to a highly efficient engine that produces optimum power for every unit of fuel, making them cost effective.

Eco friendly Performance

Dual fuel Generators are more environmentally friendly than standard generators which run on either gasoline or diesel.

Dual fuel Generators have a highly efficient engine and use cleaner propane reducing toxic gas emissions.

This generator will run off the lpg 98 % of the time, leading to a much cleaner environment ,as an example you often see these generators used on coffee bikes.

Noise Levels

Most generators come as standard as 75 debels upwards ,our Generator comes in at just 58 debels ,this is well below the standard.As an example this produces the same level of noise as a conversation.Another example is that standard Mr whippy machine creates 70 debels upwards,again the generator coming in under this level.

The Generator will be encased in a weather proof case suitable for when in use and also creates another sound barrier,as stated by Island roads ,the location its 50 metres away for nearest properties and with being encased and on the other side of the pod it will also act as a shield, it will not disturb any residents.

All of our equipment has been brought with low emissions in mind.From the ice machine to the soft serve ice cream all machines use the lowest possible power while being the most efficient.

Products

We are keen to keep Green ,all of our cups,spoons etc will be made from recyclable and biodegradable,as for packaging we will be offering a small range of bakes,crisps and ice lollies but will always encourage others to use the bin we will be supplying.

We will also be carrying out spot checks throughout the day.

The ice cream tubs will come in an edible choice to therefore further reduce rubbish .

We will be sourcing as many of our products locally as possible,including equipment, keeping the footprint even smaller.

Opening Times

I have applied for opening hours of 9 till 5

And 10 till 5 sundays,i can assure people we won't be working over these hours,These may vary in winter,maybe only trading until 2 if quiet,obviously some days we will not trade,if it's windy and raining and vey bad weather,We would never risk trying to work in these conditions and would never put the public at risk.

I hope this has helped answer some worries.

Regards Carly Sykes.

This page is intentionally left blank

From: [Wootton, Mark](#)
To: [Bull, Andrea](#)
Subject: The Salty Siren, Application for Street Trading Consent,
Date: 28 February 2024 12:42:18

Andrea,

I write further to Duncan MacDonald's 'No Adverse Comment' response on behalf of the Environmental Health Department dated 22nd January 2024 with reference to the above application.

In providing the initial response, consideration was taken in relation to the possible effects the granting of consent might have on nearby residents. Matters taken into consideration routinely under the licensing objectives of the Prevention of Public Nuisance and Public safety include the proposed hours of operation of the concession, location, proposed nature of concession, sources of noise associated with the concession, proximity to residential premises and the nature of the locality. In this case the location is a seafront roadside approximately 50 metres from the nearest residential premises which is used frequently by pedestrian and vehicular traffic.

Whilst regard for the above is commonplace, there is no requirement to document the specifics of an assessment in the event of a responsible authority having no adverse comments and/or seeking to submit a representation. This may be expected were a representation submitted either in favour or against an application. On reviewing the criteria regardless, I have the following comments which are provided in order to assist Committee Members on matters of concern raised. The further information provided by the applicant is very useful since it has provided clarity on several matters. The applicant has confirmed that it is a Champion 3000 Watt Dual Fuel Inverter Generator known as 'The Atom Fusion' and that it will run predominantly on Liquefied Petroleum Gas (LPG).

Noise

The intended operating hours are noted as Monday to Saturday 9am to 5pm and Sundays 9am to 4pm. Accordingly, the application appears to satisfy Part 10.10 of the local authority's Statement of Licensing Policy (2019-2024) given the applicant does not intend on trading during what are considered more sensitive hours, typically between 23:00 and 08:00hrs.

The 58dB(A) figure is a manufacturers stated noise level measured at 7m from the generator unit whilst it operates. Unattenuated, this corresponds to a level at 50m (the closest residential property) of 41dB(A).

I have visited the area during an afternoon and measured the background noise level at the roadside where the unit would operate from and where the noise environment was characterised by wave noise, frequent passing road traffic, pedestrians, birdsong and intermittent aircraft. The background noise level was recorded as being 40dB(A)_{L₉₀}. I note the additional comment/operational procedure that a weather enclosure will be used and that the generator will be shielded by the catering unit itself.

Practically, I would therefore expect the noise level from the generator to be below the current background noise level at residential properties. In Layman's terms I would suggest this would be unlikely to be audible within properties and whilst probably audible externally it would be considerably lower than noise from passing road traffic. Given the proposed hours of operation together with the likely noise levels, I do not consider that the use would be unreasonable and it is unlikely to constitute a public nuisance to nearby residents. Nevertheless, using the weather enclosure at all times together with the placement of the catering unit between the generator and residential properties within the proposed operational procedure appears reasonable, proportionate and practical so as to minimize any noise.

Fumes

The proposed nature of the foodstuffs proposed to be sold do not give rise to concerns in relation to adverse odour.

The proposed generator is noted to be dual fuel and can operate on both petrol and liquid petroleum gas (LPG). It is likely that there would be a significant financial saving of operating such a unit with LPG as opposed to petrol. The complete combustion of any fuel results in the production of carbon dioxide and water vapour. Realistically, some production of nitrous oxides and other combustion products is likely as well. Given that the unit will operate in the open air, environmental health have no concerns in relation to risks associated with carbon monoxide. It is noted that the generator utilises what is described as CO Shield® technology which monitors the accumulation of carbon monoxide when the generator is running and if unsafe elevated levels of CO gas are detected it automatically shuts off the engine.

Given the unit will operate in the open air and with the given separation distance to residential properties, environmental health has no concerns in relation to possible adverse effect of fumes as these are likely to be diluted and dispersed quickly. Environmental Health would not expect any fumes to be noticeable at the closest residential premises.

Safety

The generator unit is noted to have an IP rating of 'IP23M'. An IP rating is an Ingress Protection rating which is a method of showing the effectiveness of electrical equipment or fixings at preventing the ingress of dust, moisture, liquids and accidental contact. It is also noted that the unit will be operated with a 100% waterproof, heavy duty generator enclosure. Environmental Health have no safety concerns relating to the use of a generator in such circumstances provided it remains in good working order and is checked regularly for defects.

Control of Noise at Work

The stated noise level produced by the generator at 7m equates to a noise level at 1m of 75dB(A) which is below the Control of Noise at Work Regulations 2005 trigger level of 80dB(A) where employers must assess the risk to workers' health

and provide them with information and training. It is also well below the level of 85dB(A) at which employers must provide hearing protection and designate hearing protection zones. As such, environmental health have no concerns in relation to workplace noise.

Vibration

The manufacturers specification for the proposed generator does not mention vibration. Environmental Health would not expect any vibration from the generator to be detectable at any residential premise given the 50m separation distance.

In summary, Environmental Health considers that there are no fundamental matters that undermine the Prevention of Public Nuisance Objective. It is also worth noting that the Statutory Nuisance regime under the Environmental Protection Act 1990 contains provisions in relation to noise from equipment in the street which could also be utilised should any statutory nuisance unexpectedly be caused.

Please let me know if you have any queries.

Regards,

Mark Wootton, Senior Environmental Health Practitioner
Community Protection, Isle of Wight Council, County Hall, High Street, Newport,
Isle of Wight PO30 1UD
Tel: 01983 82100 Ext: 6164
Email: mark.wootton@iow.gov.uk
Web: <http://www.iow.gov.uk>

This page is intentionally left blank

GENERAL

1. Street trading must be carried out in accordance with the terms and conditions of this consent.
2. A copy of this consent must be kept on site by the holder and available for inspection by an authorised officer of the Council or a Police Officer.
3. The consent holder must at all times maintain a valid Third Party Public Liability Insurance Policy to the satisfaction of the Council and must produce a valid certificate of such insurance at any time upon request by an authorised officer of the Council.
4. The consent holder must notify the Licensing Department immediately of any convictions or proceedings arising out of the use or enjoyment of the consent.
5. The consent holder must not assign, sublet or part with his interest or possession under this consent or any part thereof, but may surrender it to the Council at any time.
6. The consent holder is responsible for all costs associated with this consent.
7. The consent holder must observe and comply with any directions in relation to the use of the street or public place by a duly authorised officer of the Council.
8. Any consent holder who wishes to employ an assistant who will be left solely in charge of the street trading site during the course of a day's trading must be required to:
 - a. Obtain written permission from the Council
 - b. Provide the name, age and address of such an assistant.
9. The consent holder must at all times conduct his business in a clean, honest, civil and business-like manner without interfering with the business of other Traders and consent holders.

SITE

10. The consent holder must ensure that all units/vehicles and all equipment associated with the trading is positioned to allow access for pedestrians, business owners and emergency vehicles. All equipment must be removed from the site by the time stated in this consent, unless otherwise agreed in writing with the Council.
11. The consent holder must remove the objects from the public highway immediately if requested to do so by the Council, its agents, contractors or licensees (including Island Roads) or by a Police Officer. The consent holder must not reposition the objects on the public highway until notified that they may do so. Under such circumstances the Council must not be liable to pay any compensation to the consent holder.
12. The consent holder must not in any way interfere with the surface of the public highway.
13. The consent holder must not place on the street or in a public place any furniture or equipment (including advertisements or signage) other than as permitted by the consent and he must maintain the same in a clean and tidy condition.
14. The consent holder must keep his trading position and the immediate area in a clean and tidy condition during any period of trading and also leave the area in a clean and tidy condition at the end of each period of use.
15. The consent holder must ensure that any spillages are promptly removed from the highway and restore the affected area of highway to a clean and safe condition. The Council will recharge the consent holder the full cost of any remedial work to remove any residual staining of the highway outside his or her premises, including the replacement of the paving stones if necessary, by pavement stones of an equivalent quality and to an equivalent standard.

16. The consent holder must not trade in such a way as to cause nuisance or annoyance to persons using the street or public place, or occupiers of premises in the vicinity. Noise from equipment used in connection with consented street trading activity must not be audible beyond 5 metres from the site.
17. The consent holder must make such provision as is necessary to prevent the deposit in any street or public place of solid or liquid refuse and must not discharge any water or effluent from the street trading activity to street surface drainage or other watercourse.
18. The consent holder must review and take necessary action to comply with the relevant sections of the Isle of Wight Fire and Rescue Services Appendix PEL/ 6.
19. Access must be maintained at all times for emergency vehicles (min 3.3m) and any temporary structures providing shelter/shade i.e. canopies, large parasols etc. that might prevent access for emergency vehicles, must be easily retractable/removable. All fire hydrants, fire exits and escapes from neighbouring buildings must be kept clear and free from obstruction at all times.

MARKET

20. The consent holder may only trade on the approved days of the **XX** Market and with the authorisation of the market organiser.
21. The granting of this street trading consent is conditional on the holder's compliance with the constitution, terms and conditions (or equivalent documentation) of the market.

MOBILE TRADING

22. Trading under this consent is not permitted in any location for longer than 60 minutes and a trader must not return to the same location within 2 hours.
23. It is an offence to sound chimes before 12 noon or after 7 pm. It is also an offence to sound chimes in such a way as to give reasonable cause for annoyance. In accordance with the Code of Practice, the consent holder must not sound chimes:
 - a. For no longer than 4 seconds at a time;
 - b. more often than once every 3 minutes;
 - c. when the vehicle is stationary;
 - d. except on approach to a selling point;
 - e. when in sight of another vehicle which is trading
 - f. when within 50 metres of schools (during school hours); hospitals and places of worship (on Sundays and other recognised days of worship);
 - g. more often than once every 2 hours in the same length of street;
 - h. louder than 80 dB(A) at 7.5 metres;
 - i. as loudly in quiet areas or narrow streets as elsewhere

REVOCATION OR SURRENDER OF CONSENT

24. This consent may be revoked by the Council at any time and the Council will not in any circumstances whatsoever be liable to pay any compensation to the holder in respect of such revocation.
25. The holder must return this consent to the Isle of Wight Council immediately on revocation or surrender of the consent.

LEGAL PROVISIONS

26. Nothing contained in these conditions will relieve the consent holder or his employees or agents from any legal duty or liability and the consent holder indemnifies the Council in respect of all claims, actions, demands or costs arising from this consent.

27. The Council may vary the conditions attached to the consent at any time.

28. This consent cannot be transferred and trading is only authorised to be carried out by the person named in the consent or a named assistant (as detailed above).

NOTES TO THE CONDITIONS

1. It should be noted that this consent does not imply any approval from another authority (such as the Highways Authority, Planning Authority or Business Rates) and does not override parking regulations.
2. Within the terms of these conditions the following works have the meanings as described:

The Council: the Isle of Wight Council

Street Trading: the selling or exposing or offering for sale of any article (including living thing) in any street

Street Includes:
a. Any road, footway, beach or other area to which the public have access without payment,
b. A service area as defined in section 329 of the Highways Act 1980 and
c. Any part of a street.

Consent Street: a street in which street trading is prohibited unless consent is given by the district council.

Authorised Officer: an officer employed by the Isle of Wight Council and authorised by the Council.

This page is intentionally left blank